

NOTES

- Manhole notes:
- 225mm (unless otherwise stated) thick C12/15 Mass Concrete Foundations.
 - Preformed half circle channel pipes. The pipeline may, where practicable, be laid through the manhole and the crown cut out to half diameter, provided flexible joints are situated on each side no further than 600mm from the inner face of manhole wall.
 - Manhole Construction. For Surface Water Manholes high density blocks to CI.S10 of IS.20 Part 1:1987 or C25/30 in situ concrete. Block work shall be bedded and jointed using mortar to IS406. Beds and vertical joints shall be completely filled with mortar as the blocks are laid. Joints shall be flush pointed as the work proceeds. All Foul Manholes must be faced in Solid Engineering Brick (min. Class A or B), or in situ concrete for 1m above Benching Level. Brick to be bonded to block work using English Garden Wall Bond.
 - Relieving arch formed by 215x103x65 solid engineering brick Class A or B as per drawing. Relieving arches used in brick or block work manholes extend over full thickness of wall. A Double Arch is to be formed for pipe diameters greater than 600mm.
 - Benching and pipe channel pipe surround - C16/20 concrete.
 - Benching finishes in 2:1 sand-cement mortar with a smooth trowel finish, at 1 in 30 slope towards channel.
 - Standard rungs at 300c/c vertically and galvanized to the latest version of B.S.729 or equivalent. Note: Steps from are **not** acceptable.
 - 600mm square ope in roof slab.
 - Pre-cast R.C. Roof Slab shall be 225mm (unless otherwise stated) thick in Class C25/30, with 40mm cover to steel.
 - 1 to 2 courses of solid engineering bricks CI.B to I.S.91:1983 set in 1:3 (cement and mortar).
 - Class D400 or E600 manhole cover and frame to IS/EN 124. 150mm deep frame for roads and 100mm deep for footpaths and green areas. Non-rock design, closed keyways, manufactured from spheroidal graphite cast iron (ductile cast iron), 600 x 600 (600 diam.) clear opening cover and frame coated in bitumen or other approved material, cover to have a minimum mass of 140kg/m², frame bearing area shall be 80,000mm² min. Frames shall be designed to prevent covers falling into manhole. Frames shall be bedded on approval mortar to manufacturers instructions.
 - Short length pipe and pipe joint external to manhole shall not exceed 600mm from the inner face of manhole wall.
 - Toe holes of 230mm minimum in depth and galvanized steel safety railings to be provided in benching of sewers greater than 525mm diameter and depth to invert >3m for access to invert.
 - A safety chain is to be provided on pipes that exceed 450mm in diameter. Mild safety chain shall be 10mm nominal size grade M(N) non-calibrated chain, type 1, complying with B.S.4942 Part 2 or equivalent.
 - When depth of manholes to invert is greater than 3.0m ladders shall be used instead of rungs to B.S.4211 or equivalent except that stringers should be not less than 55 x 12mm in section and rungs 25mm in diameter. Fixed ladders should meet the dimensional requirements of B.S.4211 or equivalent.
 - Ladder stringers should be adequately supported from the manhole wall at intervals of not more than 2.0m stringers should be bolted to cleats to facilitate renewal.
 - All ladders, rungs, handrails, safety chains, etc. shall be hot dip galvanized to B.S.729 or equivalent.
 - Step should be cut flush with the inside surface of the manhole wall so that the channel extends the full length of the manhole (except for pre-cast manholes).
 - Position of 910 square ope in intermediate roof slab. All manholes shall be watertight to the satisfaction of the Engineer. Formwork to Reinforced concrete and Mass concrete shall comply with Class 2, Section 6.2.7, B.S.8110: Part 1: 1997. Finish to the top of slabs shall comply with Type A, Section 6.2.7, B.S.8110: Part 1: 1997. Plan dimensions of manholes are based on block work having a co-ordinating size of 450 x 225 x 100. Manholes are designed to B.S.8005 and wall thickness to L.S.325 block work design code taking granular fill pressure and H.B. surcharge. Reinforcement to slabs to Engineers details.
 - For manholes >3m depth to invert use C25/30 in situ concrete. Reinforcing mesh ref. A393 @ 6.16kg/m to be fixed at mid point of wall. Additional reinforcement to be supplied over pipe crown.
 - Manholes are designed to B.S.8005 and wall thickness to L.S.325 block work design code taking granular fill pressure and H.B. surcharge. Reinforcement to slabs to Engineers details.
 - For pre-cast manholes, chamber walls & cover slab to be constructed to IS EN 1917 and IS 420 2004.
 - Manhole openings to be situated furthest from the nearest Carriageway. Manhole steps / access to be positioned to allow viewing of oncoming traffic.
 - For bedding and sealing of Chamber rings, the top ring (to Pre-cast cover slab) and bottom ring to be bedded with cement mortar. For intermediate rings, joints to be sealed with approved pre-formed jointing strip.
 - Pre cast manholes to be surrounded with a minimum of 150mm thick Grade C16/20 concrete.
- General Notes**
- All brick to be Solid Engineering Brick Class A or B.
 - For pipe diameter >750mm use manhole with internal diameter size = pipe size + 1 metre + 300mm.
 - Distance from the top rung of the ladder to ground level must be a maximum of 500mm.
- 25) This drawing to be read in conjunction with all other relevant engineer's drawings and the Great Dublin Regional Code of Practice V6.0.
- 26) Any queries or discrepancies are to be referred to the engineer immediately.
- 27) Figured dimensions only to be read. All dimensions to be checked on site.

MANHOLE TYPE J (PRECAST CONCRETE MANHOLES)

**MANHOLE TYPE K (PRECAST CONCRETE MANHOLES)
DEPTH TO INVERT 3m TO 6m**

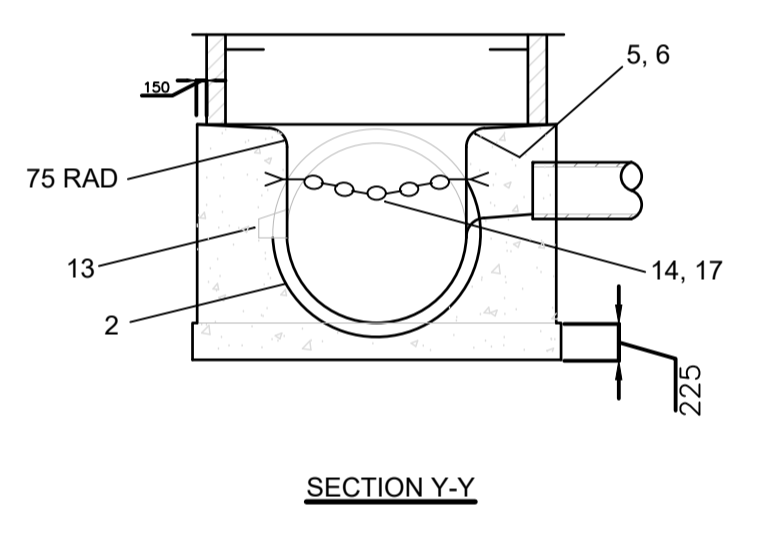
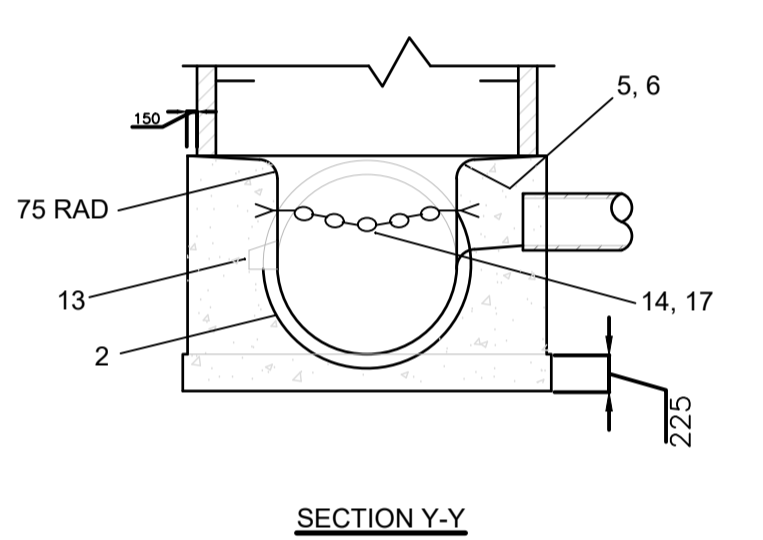
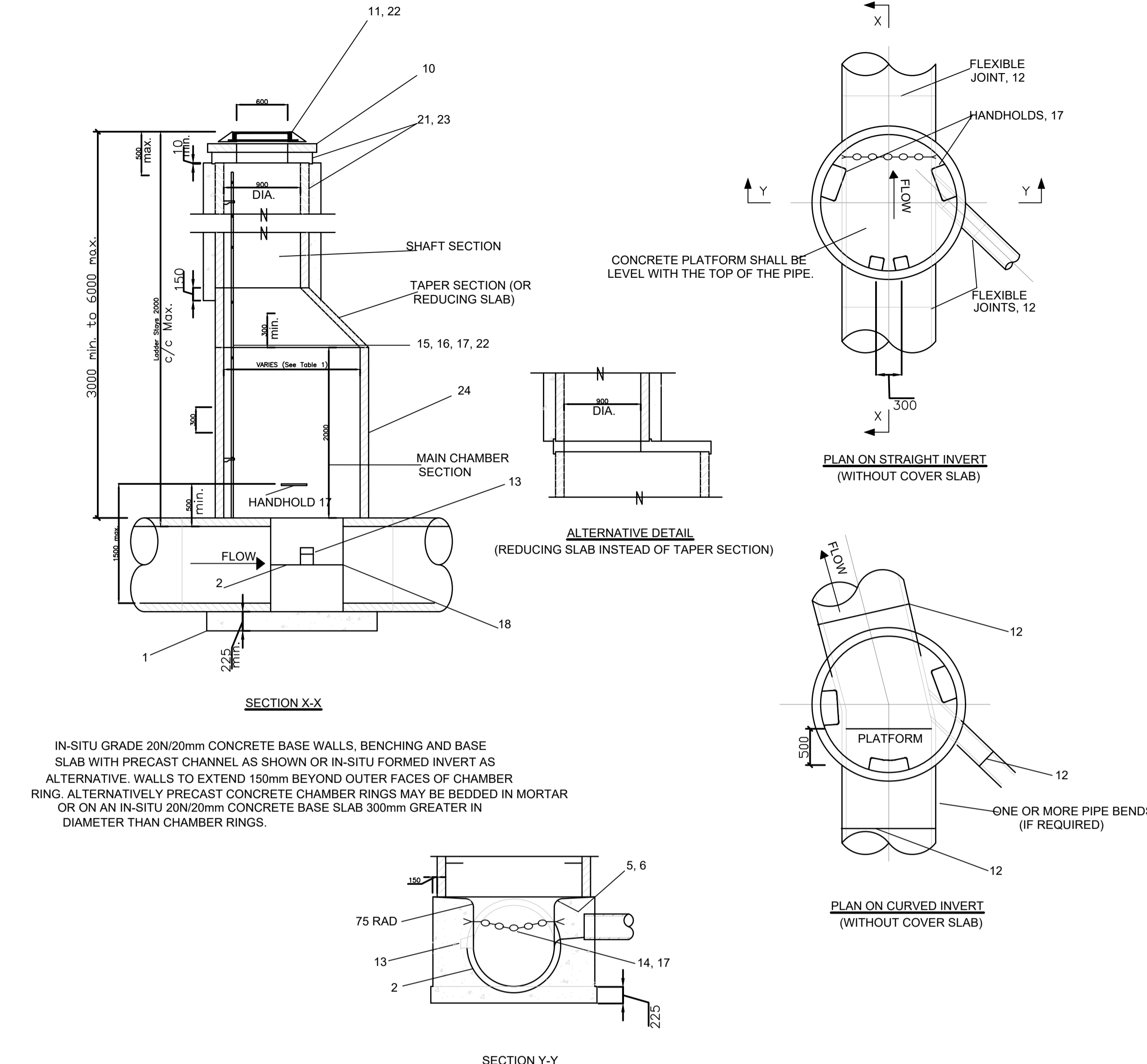
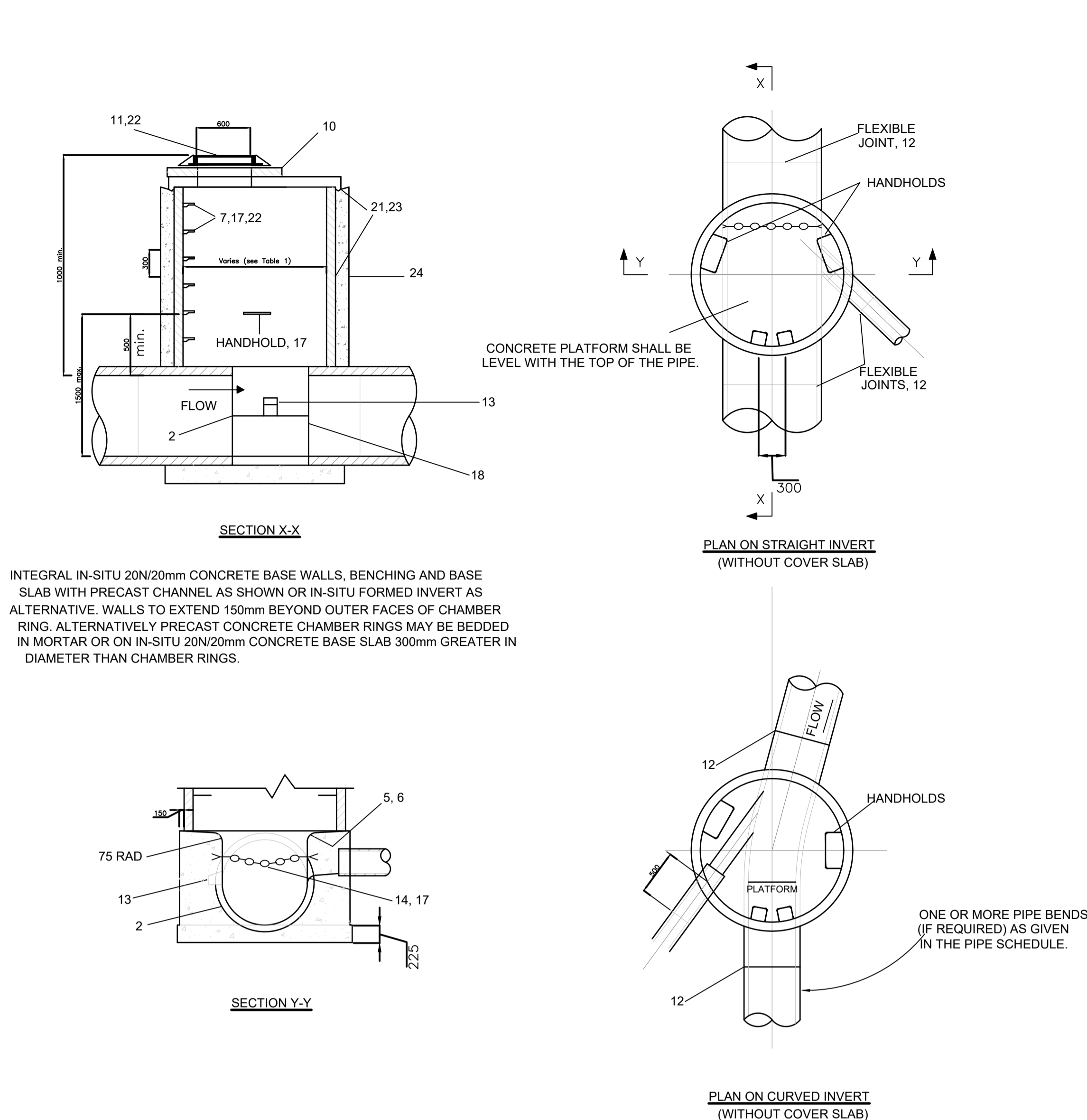

MAXIMUM PIPE DIAMETER	CHAMBER INTERNAL DIAMETER
A	B
225	1200
300	1200
375	1200
450	1200
525	1200
600	1200
675	1350
750	1350
900	1500
1050	2100
1200	2100

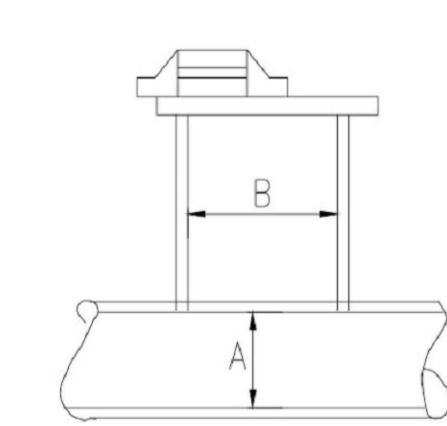

TABLE 1:

INITIAL ISSUE	ES	30.04.19	P1
Description:		Drawn	Date: Rev.:
Client:			
COSGRAVE PROPERTY GROUP.			
Project:			
BLACKWOOD SQUARE, NORTHWOOD, D9			
Clients Representative:			
J. B. Barry and Partners Limited Consulting Engineers			
Classon House Dundrum Business Park Dundrum Road Dublin 14			
Tel: +353 1 485 1400 email: info@jbbarry.ie web: www.jbbarry.ie			
Drawn By:	ES	Date:	APRIL 2019
Checked By:	GF	Date:	APRIL 2019
Approved By:	GF	Date:	APRIL 2019
Internal Project Ref:	Y19205	Stage:	PLANNING
Drawing Title:			
TYPICAL SURFACE WATER DRAINAGE DETAILS SHEET 1			
Scales:			
N.T.S.			
Drawing No.:	19205-JBB-00-XX-DR-C-01006	Rev:	P1